

AZ3 HTE 2

Pistola manual

NEW!

HTE 2

HIGH TRANSFER EFFICIENCY

Conexión aire: G1/4"
Conexión fluido: G1/4"



Modelo

AZ3 HTE2	1.0	10-15HTE	2.0	80	200	180
AZ3 HTE2	1.3	10-15HTE	2.0	140	200	240
AZ3 HTE2	1.5	10-15HTE	2.0	160	200	260
AZ3 HTE2	1.8	18-20HTE	2.0	250	215	300
AZ3 HTE2	2.0	18-20HTE	2.0	300	215	340
AZ3 HTE2	2.5	25HTE	3.0	450	280	360
AZ3 HTE2	2.8	28-30HTE	3.0	540	300	380
AZ3 HTE2	3.0	28-30HTE	3.0	560	300	400
AZ3 HTE2	3.5	35 HTE	3.0	600	300	420
AZ3 HTE2 P AV	1.3	10-15HTE	2.0	140	200	240
AZ3 HTE2 P AV	1.5	10-15HTE	2.0	160	200	260
AZ3 HTE2 P AV	1.8	18-20HTE	2.0	250	215	300
AZ3 HTE2 P AV	2.0	18-20HTE	2.0	300	215	340
AZ3 HTE2 P AV	2.5	25HTE	3.0	450	280	360



AZ3 HTE 2



AZ3 HTE 2 P

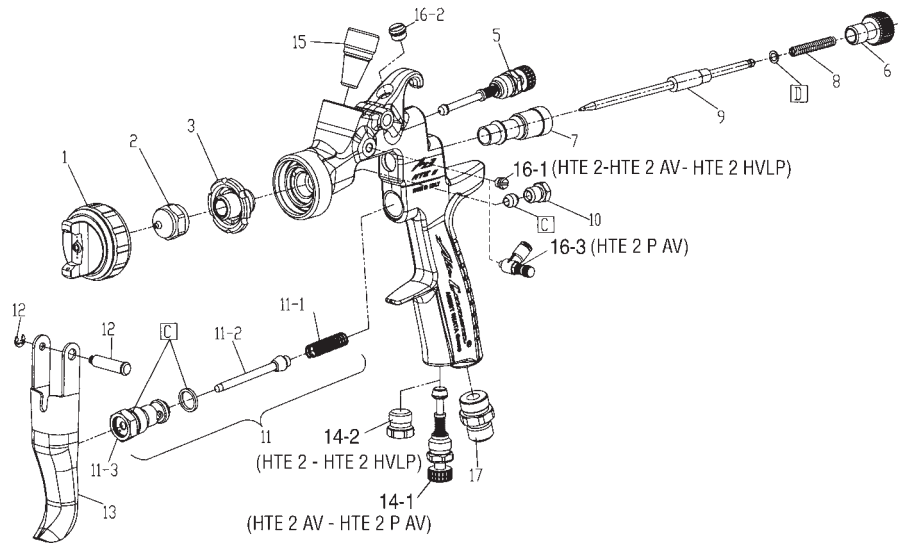

Pistola de gravedad

Certificados



VOC-00V DIRECTIVES CONFORME

Model: AZ3 HTE2
Test Authority: IPA Fraunhofer Institut
Date: 28/03/2008

THREE COAT SYSTEM
PRIMER: 87%
BASECOAT: 83%
CLEARCOAT: 74%

DECLARATION OF CONFORMITY
We AIR GUNSA s.r.l. - Corso Vigevano, 46 - 10155 Torino - Italy declare, under our sole responsibility, that the product:
AZ3 HTE2 SPRAY GUN series
to which this declaration relates, is in conformity with European ATEX Directive 94/9/CE for use in zone 1 and zone 2 and Machinery Directive 98/37/CE. According with the following international requirements: EN 1127-1, EN 292-2 and EN 1363.
Name and position of issuer: Mr. Marco G. VICENTINI, Managing Director
Date: 04/04/2008
Firma: *Marco G. Vicentini*

ATEX DIRECTIVES CONFORME